

Quality  
at its best  
MADE IN AUSTRIA



# CASA NOVA

Design, Customised to Your Requirements



---

Your continuing  
satisfaction is  
our prime  
concern here at  
Biohort.



## Dear Customer!

Biohort products offer you the best quality, functionality and security. Our customers especially appreciate the durability and low maintenance of our storage solutions.

Biohort garden sheds have proven their durability in over 45 years of outdoor service. We are an Austrian manufacturing company with highly-trained and skilled workers. Biohort uses only top-quality materials from tested suppliers to manufacture its products. The high-quality steel plate we use is supplied by the same worldwide renowned Austrian and German steelworks in which German premium car manufacturers place their trust. This is the reason why we can offer our customers a 20-year guarantee against corrosion with a clear conscience.

Sophisticated design and the high Austrian quality standard applied in the manufacturing process creates products that you will enjoy for decades.

We personally vouch for this.



Dr. Josef Priglinger  
Managing Director



Dipl.-Ing. Maximilian Priglinger  
Managing Director





# THE BIOHORT ALL-ROUND CAREFREE PACKAGE



## PRODUCT CONFIGURATOR

The new Biohort 3D configurator visualises every product with just a few clicks - including any chosen accessory - and provides you with a price right away. And this is not all: the handy augmented reality function allows you to virtually position the product directly in your garden via smart phone or tablet.

[www.biohort.com/en/configurator](http://www.biohort.com/en/configurator)



## ADVISORY SERVICE

To make sure your project works out smoothly, our experts will assist you every step of the way. E-mail enquiries via [casanova@biohort.at](mailto:casanova@biohort.at) or via phone **+43 7282 7788 0**



## ASSEMBLY SERVICE

Our well illustrated assembly manual allows for self-assembly. Upon request, our specialised assembly partners are available to install your CasaNova® accordingly.



## FOUNDATION INFORMATION

Storm resistant, secure anchorage, and protection against of water ingress are important criteria that should be considered when deciding on the type of foundation. Our foundation tips can help you further. More information on **page 15** and at

[www.biohort.com/en/service/foundation-tips1/foundation-tips-for-outbuilding-casanova](http://www.biohort.com/en/service/foundation-tips1/foundation-tips-for-outbuilding-casanova)



CasaNova® Size 3x4, Metallic Dark Grey  
 (with aluminium floor frame, double door,  
 external spotlights and two glass elements  
 as accessories)

## DESIGN, CUSTOMISED TO YOUR REQUIREMENTS

Whether as a garden shed, workshop or sauna - the insulated design outbuilding CasaNova® provides unique flexibility with a wide range of equipment options and adapts exactly to your ideas.

No matter if you are looking for functional storage and place to store your plants during winter or if you want to establish an oasis of peace in your garden: with the CasaNova® you can make your wish come true at a unique quality level.

Multiple coated steel plate guarantees durability and high corrosion resistance

- 25 µm polyamide-enamel coating
- 5 µm primer
- 1 µm undercoat
- 150g/m<sup>2</sup> galvanised
- 0,5 mm steel plate
- 150g/m<sup>2</sup> galvanised
- 1 µm undercoat
- 5 µm primer
- 15 µm polyester-enamel coating

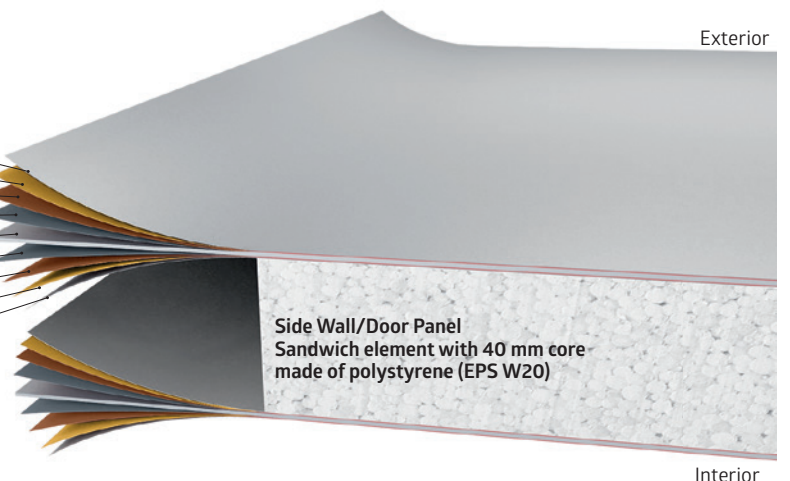





## INDIVIDUALLY PLANNABLE

Through the innovative CasaNova® with its modular construction, Biohort combines a rather free choice during planning with the advantages of a prefabricated solution. The insulated exterior walls allows for the CasaNova® to be used even on cooler days.

## COMFORTABLE IMPLEMENTATION

With its own development and production in Neufelden/Austria, Biohort is able to support the realisation of your garden dream with comprehensive services: Your personal adviser will help you with the planning, advise you on the appropriate foundation and will be happy to arrange a certified installation team if you do not wish to install your CasaNova® yourself.

## ABSOLUTELY MAINTENANCE FREE

Unlike the owners of wooden sheds, you can forgo the need to regularly retouch and paint your property! This is all thanks to the metal construction of CasaNova®. Made completely out of hot-dipped galvanised high quality sheet steel which ensures outstanding durability and makes it maintenance free.

## PERFECT METAL DESIGN

With its harmonious contours and appearance, the CasaNova® impresses from afar. On closer inspection, the beautiful surface surprises with a pleasantly warm feel thanks to high-quality polyamide enamel. It is this perfect combination of form and finish that makes it a functional design element.







# INDIVIDUALLY PLANNABLE

The CasaNova® is an eye-catcher in every location: Smooth surfaces without visible screws and soft contours ensure an incomparably elegant appearance. With nine sizes and three colours, it is suitable for every location.

Thanks to the **modular design**, there are no limits to your wishes. Doors and windows can be positioned freely according to your expectations. So your dream of your garden outbuilding becomes reality!

## COLOURS

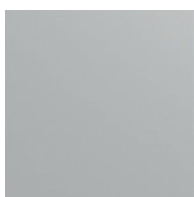

Metallic Silver

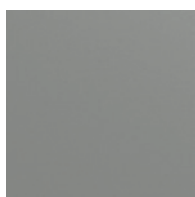

Metallic Quartz Grey



Metallic Dark Grey

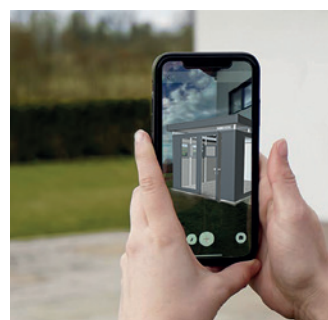

Biohort Online Product Configurator with AR function.



### SIZES (IN CM, OUTER DIMENSIONS INCL. ROOF OVERHANG)

**Door Opening:** Standard Door (right door hinge): 95 x 200 cm (W x H)

Double Door: 187 x 200 cm (W x H)

The dotted lines mark the roof overhang.

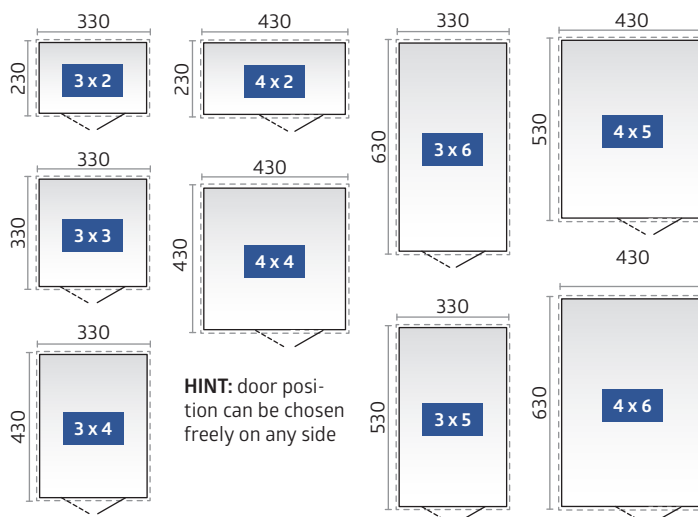

**CasaNova® 3x3, Metallic Silver**  
(with aluminium floor frame and glass element)



**CasaNova® 3x3, Metallic Dark Grey**  
(with double door, aluminium floor frame and 2 glass elements)



**CasaNova® 3x4, Metallic Quartz Grey**  
(with aluminium floor frame, double glass door and tilt and turn window)



**CasaNova® 3x3, Metallic Silver**  
(with double door, aluminium floor frame and aluminium floor plate)



**CasaNova® 3x5, Metallic Dark Grey**  
(with glass element)



**CasaNova® 3x5, Metallic Dark Grey**  
(with overhead sectional garage door, additional door and tilt and turn window)



Neufelden Facility



Packaging

## FOCUS ON PERFECTION

**We owe the excellent reputation of our products to superior design, convincing quality and uncompromising service. Based on this high level and our technical production know-how, we have further exploited our potential and developed CasaNova®: an outbuilding that offers the necessary freedom for individual design with functional wall elements and a flexible plug-in system.**

### DELIBERATE SPECIALISATION

From the very beginning Biohort has concentrated on storage space solutions made of high-quality 0.5 mm sheet steel, thus building up superior production know-how. A separate production line with predominantly manual production was set up at Biohort especially for the customised production of CasaNova®.

### HIGHLY MOTIVATED

Our dynamically structured production process makes it possible to achieve delivery times of 4 to 6 weeks. The delivery is carried out by a truck with unloading possibilities, the self-assembly of the complex house is feasible for two persons in about one day thanks to the clearly illustrated assembly instructions. A labour saving alternative is to make an appointment with a specialized assembly service team.

### PERFECT DELIVERY

During the packaging, the assembly packages are put together according to the desired design and all components are checked thoroughly before dispatch. The custom-made transport boxes guarantee damage-free delivery for a smooth, undelayed assembly of your CasaNova®.



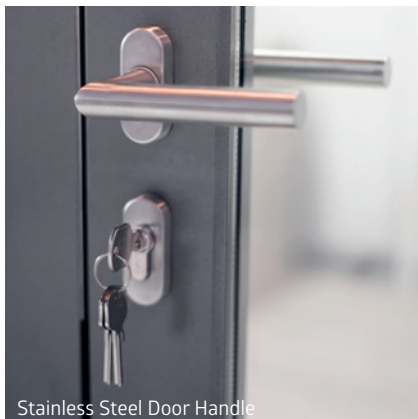
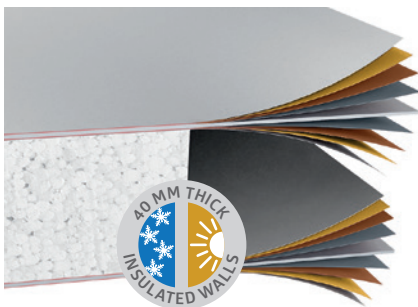

Stainless Steel Door Handle



Sliding Window in the Skylight



Roof Greening Possible



Threshold

## SMALL DETAILS WITH GREAT ADDED VALUE

**Our technicians are constantly striving to improve the gardening experience of our customers. The result of our work are the numerous details that are easily overlooked at first glance. We guarantee you however, that you will not want to go without them during your lifetime as a Casanova owner!**

### CONTINUOUS WALL AND DOOR INSULATION

The individual wall elements are fitted with a tongue and groove joint on the long sides. This guarantees absolute protection from ingress of wind and rain. Furthermore the adhesive sealing strip along the complete length of the tongue prevents the creation of a thermal bridge between the wall elements. These achieve a U-value of 0.76W/m<sup>2</sup>K (insulation value of a 35 cm hollow brick) due to the precisely cut EPS W20 core of expanded polystyrene rigid foam. If you are planning to add heating, we recommend fitting XPS Styrofoam panels available from any DIY centre under the roof and the double-glazed skylights.

### HIGH LEVEL OF SECURITY

Outbuildings are often the target of unwelcome guests. It was therefore not enough for the Biohort developers to construct a stable door. They have therefore equipped them with a high-quality stainless steel door handle set with a fully functional standard cylinder lock. This last feature is approved by insurance companies. The

height of the skylights is also a security feature, as it prevents curious glances into the interior without having to do without light.

### MULTIFUNCTIONAL ROOF STRUCTURE

The roof is constructed of plywood panels (thickness: 22 mm thick), which are laid and fixed to the roof beams. The wooden ceiling visible on the inside regulates the air humidity thanks to its hygroscopic properties. On the outside, the wooden roof is efficiently protected by a full-surface, high-quality EPDM roofing membrane (thickness: 1.52 mm). The stability of the panels and the root-resistant membrane allow for roof greening without hesitation (roof load to 215 kg/m<sup>2</sup>). Two watertight drains guarantee the drainage of rainwater from the roof.

### COMFORTABLE FEATURES

Many other details guarantee long lasting pleasure with the CasaNova®: The high-quality gas spring from a certified supplier in the automotive industry dampens the door movement. For pleasant ventilation, the acrylic glass skylight in the standard version can be opened on two sides. And the almost flush fitted threshold allows you to move all types of garden equipment in and out of CasaNova®, smoothly and effortlessly.







CasaNova® 3x4, Metallic Dark Grey  
(with aluminium floor frame, double door, 2 glass elements, external lighting and sauna as accessories)

## INTELLIGENT ELEMENTS

The modular wall elements make individual customisation of each outbuilding easy and allow you to adapt the function to match your own personal requirements and equip it accordingly. And with the elegant exterior lighting you can impressively present your CasaNova®.



### ADDITIONAL DOOR

This practical side door can be fitted into any wall of the CasaNova®. The wall element is supplied complete with stainless steel door handle, standard cylinder lock, gas spring and floor threshold. You can select the hinge position (left or right side) to suit your requirements.



### DOUBLE DOOR

With the help of a second door, a 187 cm wide opening can be created. This makes entering and leaving the shed with large tools and equipment easier. Due to the 3-way locking mechanism, the second door not only stands for comfort but also for security.





### DOUBLE GLAZING

The double-glazing of the all-around acrylic skylight helps to improve the insulation even further. (Attention: ventilation function not applicable!)



### FULL LENGTH GLASS ELEMENT

It brings more light and cosiness. The wall elements with an insulated glass area of 83 x 181 cm (W x H) can also be positioned next to one another depending on wall length.



### TILT AND TURN WINDOW

The prefabricated wall element comes equipped with a high quality aluminium window unit, fitted with double-glazing (frame size: 83 x 65 cm) and will increase the illumination and ventilation of your outbuilding.



### GLASS DOOR

Doors made of insulated glass make your CasaNova look particularly inviting and flood it with daylight. So you can enjoy the idyll of the garden optimally from the inside. Also available as a double door.



### EXTERNAL LIGHTING

Optional outdoor lighting can be prepared to create an atmospheric setting: the milled openings (Ø 6.8 cm) can be positioned on all sides under the eaves and allow two to six lights (depending on building size) to be fitted. Please note: Spotlights are not included in the scope of delivery.

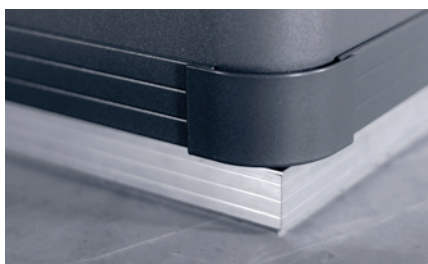

### ALUMINIUM FLOOR FRAME

Increased stability without a concrete foundation – the floor frame provides the essential conditions for installation on a level gravel base with compacted subsoil or on a concrete point foundation. The aluminium floor frame is a prerequisite for fitting aluminium floor panels.



### SECTIONAL OVERHEAD DOOR

The door from the well-known manufacturer Hörmann is intended for installation on the front or rear wall instead of the standard door. Opening: 236 x 200 cm (W x H). It is available for all CasaNova® models except 3x2 m and 4x2 m. The 42 mm thick slats offer exceptional strength and insulation. An electric opener with remote control is optionally available (not for CasaNova® 3x3 m).





**CasaNova® 3x4, Metallic Dark Grey**  
 (with aluminium floor frame, aluminium floor panels, double door, external lighting and two glass elements as accessories)

## INTERIOR FITTINGS, TO FULFIL YOUR WISHES

The CasaNova® offers a variety of uses thanks to insulation and free planning with clever window and door elements. The diversity of the Biohort accessory range increases the possibilities – from practical storage solutions to our complete sauna package.



### SAUNA MODULE

With the Biohort Thermarium available in a pentagonal design, you can fulfil the dream of owning your own sauna. With a surface area of 200 x 200 cm (interior dimensions: 180 x 180 cm), it will comfortably accommodate two people. The 6 kW sauna heater provides the necessary heat, which is infinitely variable via a user-friendly control unit. Scandinavian spruce guarantees the original Finnish sauna character. The Thermarium is fully equipped with corner lights, comfortable loungers, an hourglass, thermometer and complete infusion package. So you can immediately enjoy the pleasure of your own sauna!



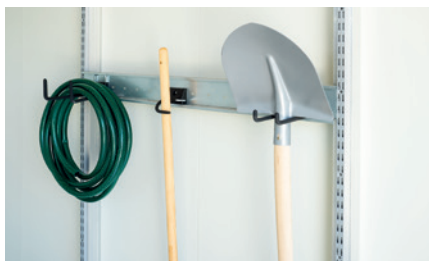

### HOOK SET

The set, consisting of a combination hook, handle hook and shovel hook, is hung on the wall between two supports rails.



### SHELF SYSTEM

The support rails are fitted directly onto the aluminium roof supports. The shelves (depth: 24.5 or 43 cm) can be hung at any height.



### FOLDING TABLE

Quickly provides you with a solid working area with a size of 96 x 57.5 cm (L x W). Simply slot into two shelf support rails and fold away when not required.

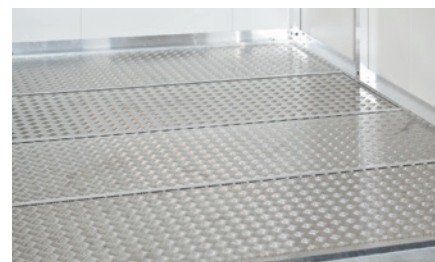

### ALUMINIUM FLOOR PANELS

Quick and easy to install, high-quality and stable. The aluminium chequer floor panels consists of several panels and connecting rails. To ensure the optimal fitting the aluminium floor frame is necessary.



### ELECTRIC MOUNTING PANEL

Discreet, hidden cable routing and easy assembly of switches and sockets (electrical equipment in photo not included). Available also in the same colour as the interior of the outbuilding at an extra cost.



### ROOF SUPPORT IN GREY WHITE

The roof supports in the wall's interior colour make your CasaNova® look even more elegant, which is particularly useful when used for purposes other than pure storage. The interior immediately appears more inviting and comfortable.



### BIKE HANGER "BikeMax"

The hanger is simple and convenient to install, height adjustable in 11 different positions and designed for bicycles of all sizes. An integrated loop for a padlock is included with each "BikeMax".

# TECHNICAL DATA

Valid from the 1st of January 2021 to the 31st of December 2021 for the United Kingdom.

Size	Exterior Base Dimensions	External Dimensions incl. Roof Overhang	Interior Dimensions (Without Supports)	Foundation Dimensions	Weight	Door Hinge	EAN Code		
							(m)	W x L (cm)	W x L x H (cm)
3 x 2	300 x 200	330 x 230 x 250	292 x 192 x 229	304 x 204	510	Right	9003414 51010 4	9003414 53010 2	9003414 52010 3
	300 x 200	330 x 230 x 250	292 x 192 x 229	304 x 204	510	Left	9003414 51014 2	9003414 53014 0	9003414 52014 1
3 x 3	300 x 300	330 x 330 x 250	292 x 292 x 229	304 x 304	630	Right	9003414 51011 1	9003414 53011 9	9003414 52011 0
	300 x 300	330 x 330 x 250	292 x 292 x 229	304 x 304	630	Left	9003414 51015 9	9003414 53015 7	9003414 52015 8
3 x 4	300 x 400	330 x 430 x 250	292 x 392 x 229	304 x 404	750	Right	9003414 51012 8	9003414 53012 6	9003414 52012 7
	300 x 400	330 x 430 x 250	292 x 392 x 229	304 x 404	750	Left	9003414 51016 6	9003414 53016 4	9003414 52016 5
3 x 5	300 x 500	330 x 530 x 250	292 x 492 x 229	304 x 504	870	Right	9003414 51013 5	9003414 53013 3	9003414 52013 4
	300 x 500	330 x 530 x 250	292 x 492 x 229	304 x 504	870	Left	9003414 51017 3	9003414 53017 1	9003414 52017 2
3 x 6	300 x 600	330 x 630 x 250	292 x 592 x 229	304 x 604	990	Right	9003414 51018 0	9003414 53018 8	9003414 52018 9
	300 x 600	330 x 630 x 250	292 x 592 x 229	304 x 604	990	Left	9003414 51019 7	9003414 53019 5	9003414 52019 6
4 x 2	400 x 200	430 x 230 x 250	392 x 192 x 224	404 x 204	650	Right	9003414 51020 3	9003414 53020 1	9003414 52020 2
	400 x 200	430 x 230 x 250	392 x 192 x 224	404 x 204	650	Left	9003414 51024 1	9003414 53024 9	9003414 52024 0
4 x 4	400 x 400	430 x 430 x 250	392 x 392 x 224	404 x 404	890	Right	9003414 51022 7	9003414 53022 5	9003414 52022 6
	400 x 400	430 x 430 x 250	392 x 392 x 224	404 x 404	890	Left	9003414 51026 5	9003414 53026 3	9003414 52026 4
4 x 5	400 x 500	430 x 530 x 250	392 x 492 x 224	404 x 504	1010	Right	9003414 51023 4	9003414 53023 2	9003414 52023 3
	400 x 500	430 x 530 x 250	392 x 492 x 224	404 x 504	1010	Left	9003414 51027 2	9003414 53027 0	9003414 52027 1
4 x 6	400 x 600	430 x 630 x 250	392 x 592 x 224	404 x 604	1130	Right	9003414 51028 9	9003414 53028 7	9003414 52028 8
	400 x 600	430 x 630 x 250	392 x 592 x 224	404 x 604	1130	Left	9003414 51029 6	9003414 53029 4	9003414 52029 5
<b>Doors and Window</b>									
<b>Double Door Panel</b>						Right	9003414 51041 8	9003414 53041 6	9003414 52041 7
						Left	9003414 51045 6	9003414 53045 4	9003414 52045 5
Optional: installation in sidewall (except sizes 3x2 and 4x2)									
<b>Glass Door (Standard Door)</b>						Right	9003414 51039 5	9003414530393	9003414 52039 4
Can be ordered additionally or instead of the standard door.									
<b>Glass Door (Double Door Panel)</b>						Left	9003414 51040 1	9003414530409	9003414 52040 0
Optional: installation in sidewall (except sizes 3x2 and 4x2)									
<b>Additional Door</b>						Right	9003414 51051 7	9003414 53051 5	9003414 52051 6
						Left	9003414 51055 5	9003414 53055 3	9003414 52055 4
<b>Tilt and Turn Window</b>						Right	9003414 51031 9	9003414 53031 7	9003414 52031 8
						Left	9003414 51035 7	9003414 53035 5	9003414 52035 6
<b>Glass Element</b>							9003414 51038 8	9003414 53038 6	9003414 52038 7
<b>Coated Roof Support</b>							upon request	upon request	upon request
Accessories	for size		Version		EAN Code				
<b>Sectional Overhead Door**</b> (standard door is omitted)	3 x 3 - 3 x 6   4 x 4 - 4 x 6		Silver Without Electric Opener		9003414 50051 8				
	3 x 4 - 3 x 6   4 x 4 - 4 x 6		Silver With Electric Opener***		9003414 50055 6				
<b>Threshold Access Ramp</b>	For Double Door				9003414 50090 7				
	For Sectional Overhead Door				9003414 50092 1				
<b>Bicycle Hanger "BikeMax"</b>	For All Sizes		1 Piece Per Package		9003414 50085 3				
			2 Pieces Per Package		9003414 50086 0				
<b>Shelf Support Rails</b>	For All Sizes		2 Pieces Per Package		9003414 50082 2				
<b>Hook Set</b>	3 x 3 - 3 x 6   4 x 4 - 4 x 6		99 cm Width		9003414 50087 7				
	For All Sizes (in corner)		93 cm Width		9003414 50097 6				
<b>Shelves</b>	3 x 3 - 3 x 6   4 x 4 - 4 x 6		24.5 x 99 cm, 2 Pieces Per Package		9003414 50088 4				
			43.5 x 99 cm, 2 Pieces Per Package		9003414 50089 1				
	For All Sizes (in corner)		24.5 x 93 cm, 2 Pieces Per Package		9003414 50098 3				
			43.5 x 93 cm, 2 Pieces Per Package		9003414 50099 0				
<b>Folding Table</b>	3 x 3 - 3 x 6   4 x 4 - 4 x 6		96 x 57.5 cm		9003414 50080 8				
<b>Electric Mounting Panel</b>	For All Sizes		Uncoated		9003414 50083 9				
			Coated		9003414 50084 6				
<b>Sauna Module</b>	3 x 3 - 3 x 6   4 x 4 - 4 x 6		Right Door Hinge		9003414 50250 5				
			Left Door Hinge		9003414 50150 8				
<b>Preparation for External Lighting</b>	2 m Side		2 Cutouts (Ø 6.8 cm)		9003414 50042 6				
	3 m Side		3 Cutouts (Ø 6.8 cm)		9003414 50043 3				
	4 m Side		4 Cutouts (Ø 6.8 cm)		9003414 50044 0				
	5 m Side		5 Cutouts (Ø 6.8 cm)		9003414 50045 7				
	6 m Side		6 Cutouts (Ø 6.8 cm)		9003414 50046 4				



Accessories	Aluminium Floor Frame	Aluminium Floor Panels	Double Glazed Acrylic Glass Skylight
for size	EAN Code	EAN Code	EAN Code
3 x 2	9003414 50010 5	9003414 50030 3	9003414 50021 1
3 x 3	9003414 50011 2	9003414 50031 0	9003414 50022 8
3 x 4	9003414 50012 9	9003414 50032 7	9003414 50023 5
3 x 5	9003414 50013 6	9003414 50033 4	9003414 50024 2
3 x 6	9003414 50014 3	9003414 50034 1	9003414 50025 9
4 x 2	9003414 50015 0	9003414 50035 8	9003414 50026 6
4 x 4	9003414 50016 7	9003414 50036 5	9003414 50027 3
4 x 5	9003414 50017 4	9003414 50037 2	9003414 50028 0
4 x 6	9003414 50018 1	9003414 50038 9	9003414 50029 7

\*\*Standard door + 1 panel already subtracted from price \*\*\* 1 remote control incl. in delivery

# HAVE YOU THOUGHT ABOUT THE FOUNDATION?



More Information:  
[biohort.com/foundation](http://biohort.com/foundation)

A foundation must be carefully planned and built. A professional should determine the appropriate foundation with the necessary depth, width and the type and position of reinforcement required for the particular type of soil. A foundation allows the CasaNova to be fastened to it securely against storms, offers torsional freedom and protection against water ingress.

## 1) CONCRETE FOUNDATION

The most durable and proven method is a concrete foundation, which is especially necessary for a loose soil type. This flat base enables quick and uncomplicated assembly. On these you can mount the CasaNova storm-proof. Screws and plastic anchors are included in the standard delivery. The concrete foundation should be only slightly larger than the surface area itself, about 2 cm per side.

**a) Concrete Foundation - floor frame necessary (sauna solution with tiled floor)**

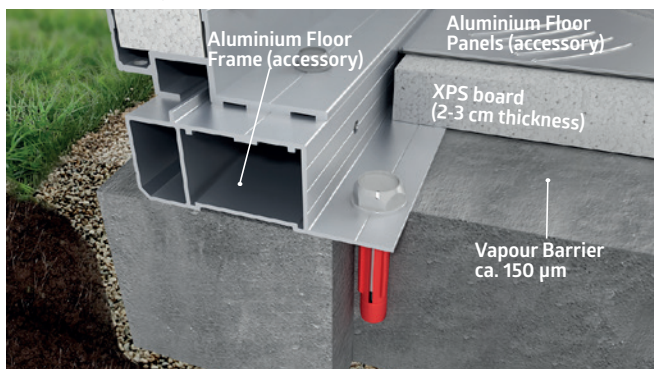

**b) Step Foundation - no floor frame necessary**

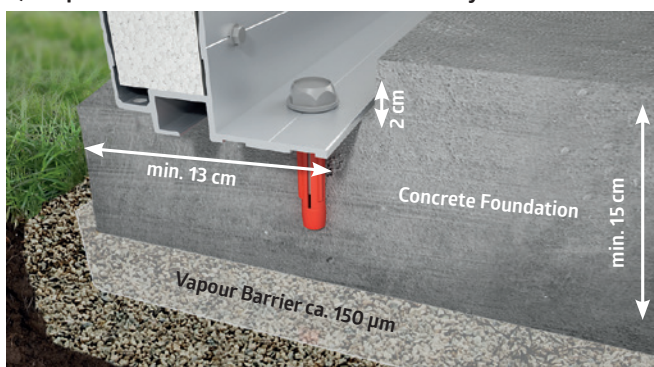

## 2) POINT AND STRIP FOUNDATIONS

Further possibilities, which however are only possible on dense and set load-bearing soil, are the strip and point foundations. Minimum depth 80 cm and minimum width 30 cm.

**a) Strip Foundation: These footings, which follow the course of the side walls, offer the possibility of storm-proof fastening of the CasaNova with the aluminium floor frame.**

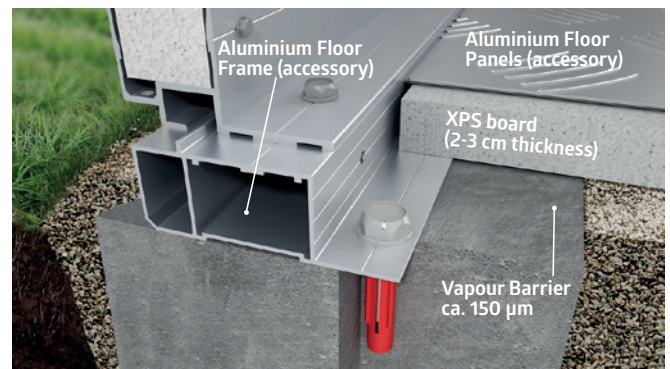

**b) Point Foundation: Certainly more complex, but also possible. Attachment is the same as with the strip foundation.**

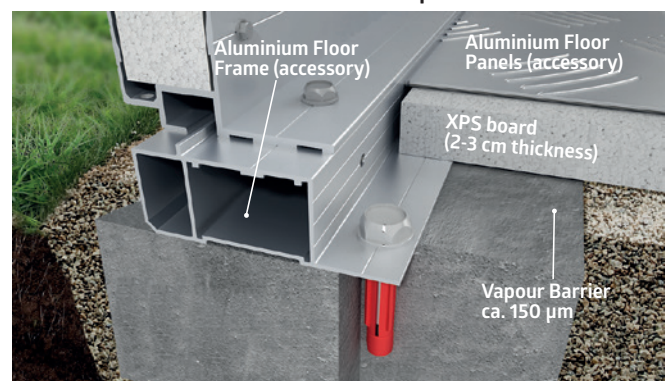

Biohort  
stands for  
"Life in the  
garden"



**Garden Sheds**  
Rely on Quality & Longevity



**Outdoor Boxes**  
Outdoor Boxes for the Garden, Patio & etc.



**Bicycle Storage**  
Bicycles, Scooter & etc Safely Stowed



**Dustbin Storage**  
Stylish, Practical & Maintenance Free



**Gardening Helpers**  
Garden Design at its Best

Your specialist dealer: